

8 Knightsbridge Green, SW1X 7QL

SHOP TO LET

568 sq ft/ 52.74sq m

Location

Based in the heart of Knightsbridge linking Brompton Road with Knightsbridge located directly opposite The Bulgari Hotel. A minute's walk from both Harrods, Harvey Nichols, and Knightsbridge tube station (Piccadilly Line). Other near by notable occupiers – Zuma, Rolex, Samer Halimeh Jewellery

Description

The premises have been refurbished to an exceptional standard and are arranged over 3 floors with no expense spared. Extensive CCTV, safes, interior designed premises with a beautiful original Victorian staircase wonderfully restored to its former glory.

Floor Area

568 sq ft/ 52.74sq m

Lease

An assignment of the existing full repairing & insuring lease for a term expiring 9th May 2031

Rent -

£125,000 per annum exclusive

Business Rates

Ratable Value £22,750

Rates Payable £11,352 (2023 – 2024)

Legal Costs -

Each party to be responsible for their own legal costs

Viewing -

Strictly by appointment by sole agents Ovington Property

EPC -

An Energy Performance Certificate is available upon request



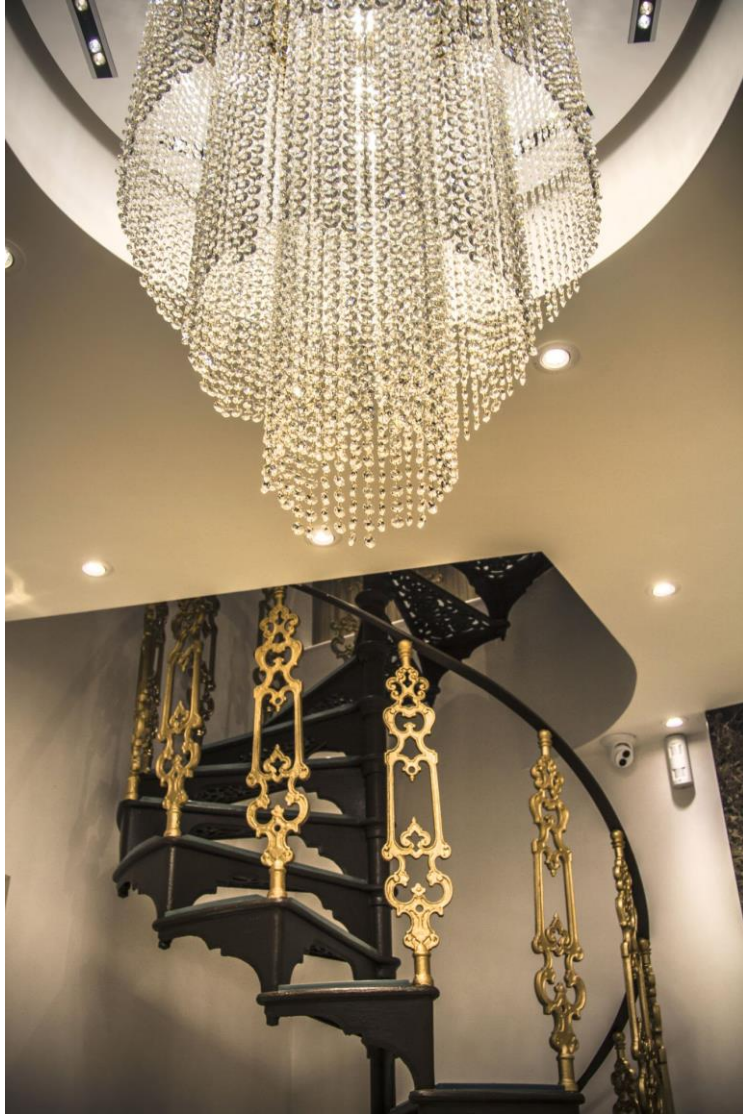

Knightsbridge Green

Approximate Gross Internal Area
568 sq ft / 52.74 sq m

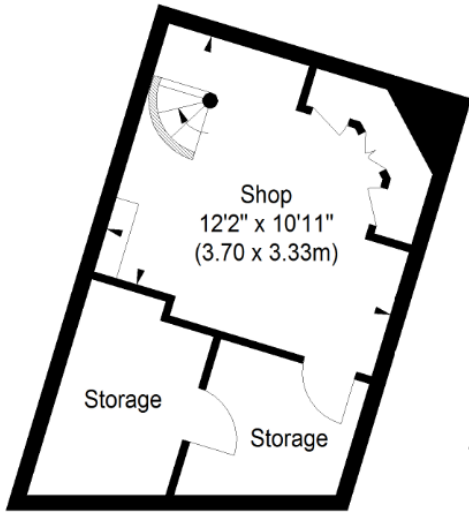

Basement

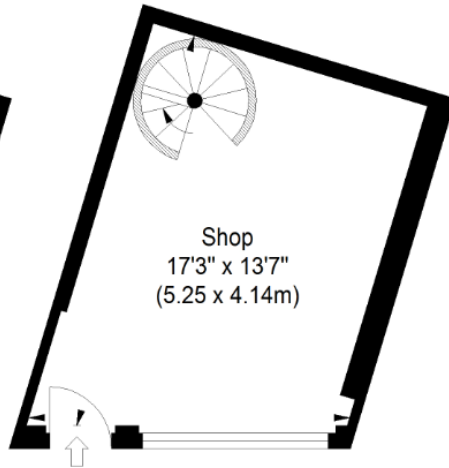

Ground Floor

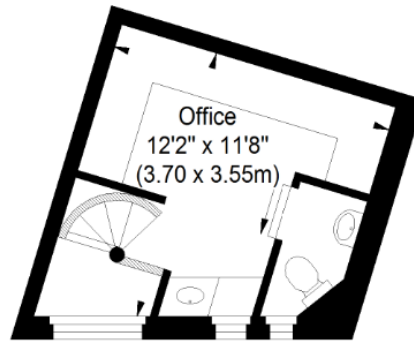

First Floor

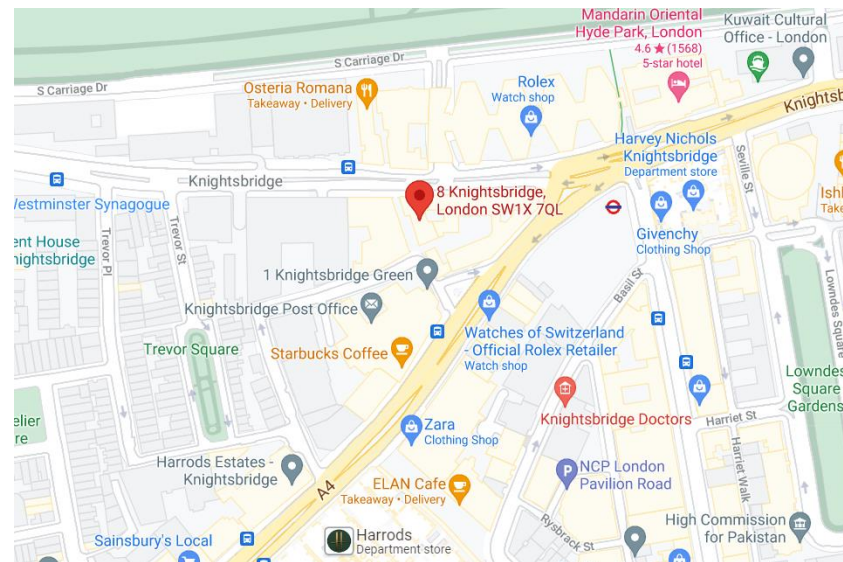

Oliver Dodd
07789278915
oliver@ovingtonproperty.com

David Hodges
07767840857
david@ovingtonproperty.com

020 7589 5221
info@ovingtonproperty.com
ovingtonproperty.com

50 Beauchamp Place
Knightsbridge
London SW3 1NY

These particulars are for general guidance only. Sizes dimensions descriptions and costs shown are approximate. Floorplan for guidance only, not to scale or valuation purposes. It must not be relied upon as a statement of fact. All measurements and areas are approximate.

21/04/21 OVINGTON – 120312-06GG